

Limpiadora de cereales CL-100 / Screen Cleaner CL-100

FUNCIÓN

La limpiadora de Cereal CL 100 es una máquina extremadamente versátil diseñada para poder abarcar la limpieza de una amplia gama de semillas. Con estas máquinas, se puede obtener un rendimiento elevado de producto final. Son muy utilizadas antes del almacenamiento en silo o en la primera etapa de limpieza de la semilla o el grano en la planta.

La Limpiadora CL-100 está disponible en varios tamaños y diseños para diferentes propósitos.

FUNCTION

The screen cleaner CL 100 is a extremely versatile machine, designed to clean a wide range of seed. They are used normally, as a first step, in the cleaning of seed, grain or before storage. The CL-100 Cleaner is available in several sizes and designs for different purposes.

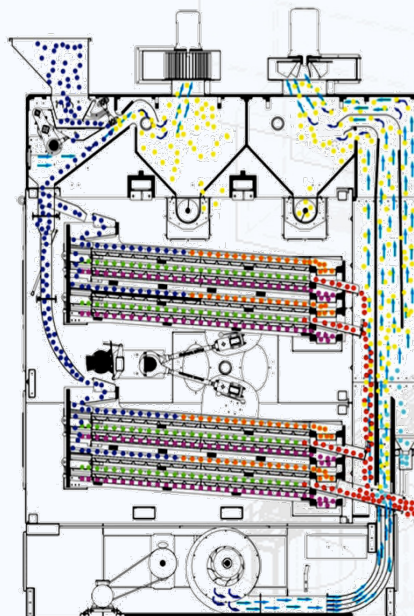

- Semilla sin tratar
Untreated seed
- Canal 1: flujo superior
Chute 1: overflow
- Canal 2: flujo inferior
Chute 2: underflow
- Canal 3: flujo intermedio
Chute 3: intermediate flow
- Canal 4: primera limpieza
Chute 4: first cleaning
- Canal 5: cuerpos ligeros
Chute 5: light seed
- Flujo de aire
Air flow

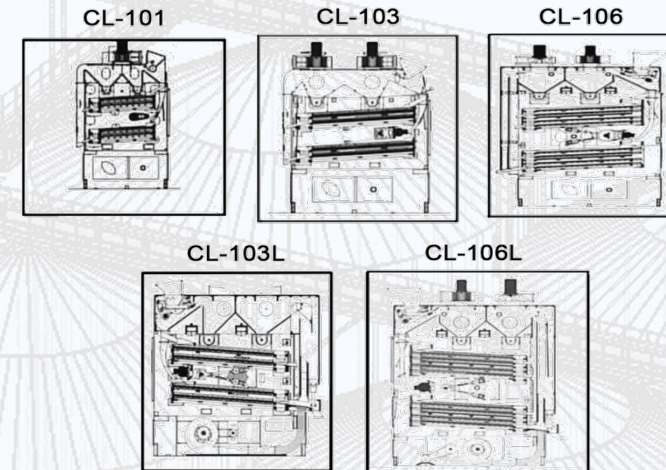

La limpiadora de Cereales CL-100 somete la semilla sin limpiar primero a una corriente de aire, que elimina las partículas de polvo, pajas, hojas, etc.

Las impurezas grandes se quitan mediante la criba superior o de tierra. Las impurezas mas gruesas que la criba va a limpiar (por ejemplo vezas grandes y maíz, en el caso del trigo, centeno o cebada) son eliminadas por la segunda criba o criba de grano. La tercera criba del conjunto (criba clasificadora), separa impurezas pequeñas relativamente pesadas, tales como arena y semillas de malezas. Antes de abandonar la máquina, la semilla es nuevamente sometida a una corriente de aire, la cual quita semillas de tamaño normal pero de peso inferior.

Within the Cleaner CL100 the seed pass through to a air flow to takes out dust, straw, leaves, etc. The biggest impurities are cleaned by the top and/or the lower Sieve. The thickest impurities that the Seed Cleaner will clean (large vetches and corn, for wheat rye or barley) are taken out by the Grain Sieve. The third Sieve, or classifier screen separates very heavy small impurities (Sand and weed seeds). Before the product goes out of the machine, the seed goes through another flow of air, which separates normal seeds with low weight, from the final product.

Engineering 2.1 – Where technology meets people

A new world of possibilities that you never dreamed of

Nuestra marca exclusiva
Our exclusive brand



BALLARINI SOCAMA
Italian Technology since 1884

NIKAMI ENTERPRISE, S.L.
 Avinguda Cambra de Comerç, 42
 Tecnoparc Edifici CEPID
 43204 Reus (Tarragona) - SPAIN
 Tel : +34 877 449 842
 Fax : +34 977 276 965
 Web : www.nikami.eu
 E-mail : info@nikami.eu

TABLA DE CAPACIDADES CL-100 / CAPACITY CHART CL-100.

	Modelo / Model	CL-101	CL-103	CL-103L	CL-106	CL-106L	
Detalles de criba / Screen details	Área de criba / Screen area (m ²)	2	8	12	16	24	
	Criba / Screen	Ancho / Width (cm)	50	100	125	100	125
		Long. / Length (cm)	100	200	240	200	240
	Cribas por caja / Screens per box	4	4	4	4	4	
	Pisos por caja / Counter Flow	2/2	2/2	2/2	4/4	4/4	
	Potencia / Power (kW)	3,7	10,2		18,8		
Cereales / Cereals (t/h)	Trigo, centeno, Sorgo / Wheat, Rye, Sorghum	2	10	12,5	20	25	
	Cebada / Barley	2	10	12,5	20	25	
	Avena / Oat	1	8	10	16	20	
	Maíz / Maize	1	8	10	16	20	
	Arroz int. / Raw Rice	1	8	10	16	20	
	Arroz blanco / White rice	1	8	10	16	20	
Legumbres / Legumes (t/h)	Soja / Soya beans	2	10	4,0	20	25	
	Guisante / Pea	2	10	4,0	20	25	
Otros Productos / Other Products (t/h)	Semilla de colza / Rape Seed	0,5	2,5	3	5	7	
	Semillas de Girasol / Sunflower seeds	0,5	2	2,5	4	6	
	Remolacha Azucarera / Sugar Beet	0,4	2	2,5	4,5	6	
	Café crudo / Raw Coffee	0,8	5	7	10	12,5	
	Café tostado / Roasted coffee	0,5	3	4	6	7,5	
Rendimiento en Pre-Limpia CL-100 / Performance in Pre Cleaner CL-100 (t/h)							
	CL-101	CL-103	CL-103L	CL-106	CL-106L		
Trigo / Wheat	6	25	37	50	75		

Ballarini Socama is a registered Brand of Nikami

* Nos reservamos el derecho de efectuar modificaciones en nuestros fabricados, sin previo aviso.
 * We reserve the right to make any modifications in our products or designs, without any notice.

A new world of possibilities that you never dreamed of



Limpiadora de cereales CL-100
 Screen Cleaner CL-100

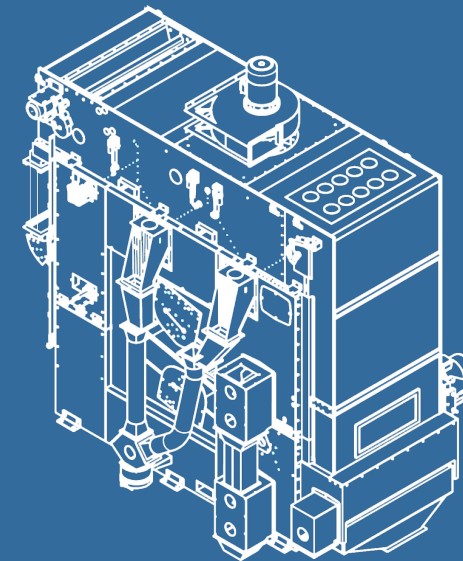

Engineering 2.1 – Where technology meets people

