

Pre-Limpiadora de cereales CL-240/ pre-Screen Cleaner CL-240

FUNCIÓN

Las limpiadoras de cereales CL-240 aseguran una excelente limpieza de todo tipo de cultivos tal y como, semillas de jardín, semillas de hierbas, semillas de flores, maíz, legumbres, etc. Estas máquinas son muy utilizadas antes del almacenamiento en silo, secado o como la primera etapa de limpieza de la semilla o el grano en la planta. El rendimiento de estas máquinas se diferencia con el de la limpieza normal en que con ellas se pueden separar productos más pequeños que se encuentran en el cultivo principal. Estas limpiadoras de cereal son máquinas muy versátiles diseñadas específicamente para la limpieza, usando unas cribas con un área de 5 a 15 m² combinado con un sistema de aspiración sofisticado. Las limpiadoras tienen capacidades con un rango que va desde 5 t/h hasta 100 t/h. La perfecta simbiosis entre la carrera i frecuencia del área de cribas de la máquina se complementa con el sistema de succión que actúa antes y después de la separación de los productos ligeros como paja, granos ligeros, etc.

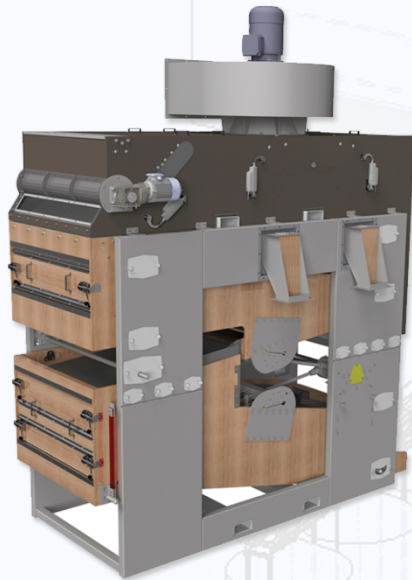

FUNCTION

The Pre-Screen Cleaners PCL-240 ensure excellent efficiency and purity in the cleaning of all kinds of crops such as garden seeds, grass seeds, flower seeds, corn, leguminous seeds, etc.

This machines are used for cleaning the material before it's stored, drying or before the first stage of the cleaning of seed or grain. This machines differ from rough cleaning as it is able to separate products smaller than the main crop.

This machine is a versatile screen cleaner using a screen area ranging from 5m² to 15m² in conjunction with a sophisticated aspiration system.

There are various models with capacities ranging from 5t/h to 100t/h.

The machine's screen area with its accurately matched stroke and frequency is complemented by it's highly efficient pre- and after-suction system for separation of light products such as chaff, straw, light grain, etc..

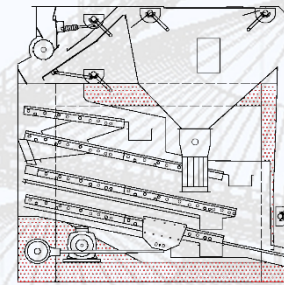

PCL 242

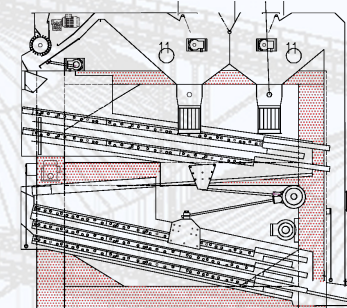

PCL 246

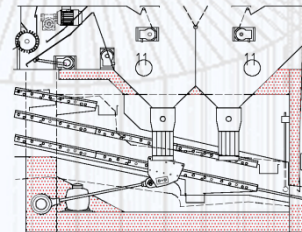

PCL 243

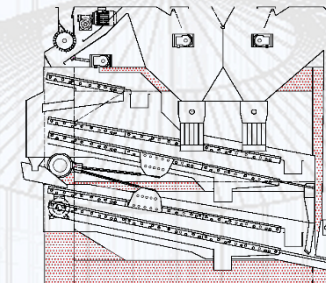

PCL 245

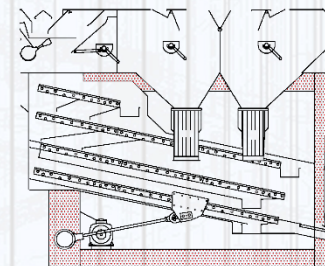

PCL 244-1

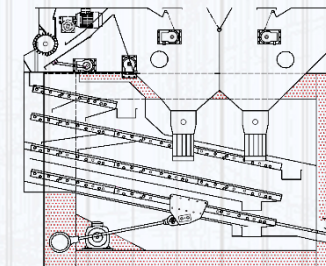

PCL 244

Engineering 2.1 – Where technology meets people

A new world of possibilities that you never dreamed of

Nuestra marca exclusiva
Our exclusive brand



BALLARINI SOCAMA
Italian Technology since 1884

NIKAMI ENTERPRISE, S.L.
 Avinguda Cambra de Comerç, 42
 Tecnoparc Edifici CEPID
 43204 Reus (Tarragona) - SPAIN
 Tel : +34 877 449 842
 Fax : +34 977 276 965
 Web : www.nikami.eu
 E-mail : info@nikami.eu

RENDIMIENTOS MAQUINARIA / MACHINE PERFORMANCE

	242	243	244-1, 244	245	246
Pre Limpieza (max 20% humedad) / Pre-Cleaning (max 20% moisture)	t/h	t/h	t/h	t/h	t/h
Trigo y cebada / Wheat and barley	30	45	50	60	100
Semilla de colza / Rape seed	25	35	40	50	90
Maiz / Maize	25	35	40	50	90
Guisantes /Peas	25	35	40	50	90
Arroz Paddy / Paddy rice	12,5	17,5	20-25	30-35	45-50
Girasol (14% humedad) / Sun flower (14% moisture)	12,5	17,5	20-26	30-36	45-51
Limpieza (max 15% humedad) / Fine cleaning (max 15% moisture)	t/h	t/h	t/h	t/h	t/h
Cebada cervecera / malting barley	3-5	5-8	6-10	10-15	15-25
Grano de semilla / seed grain	1-3	3-5	4-6	6-8	8-12
Semilla de colza / Rape seed	1-3	3-6	4-6	6-8	8-12
Mais y guisantes / maize and peas	1-3	3-4	4-5	6-8	20
Area de criba / Total screen area (m²)	5	7	10	13	15
Dimension total / overall dimension	mm	mm	mm	mm	mm
Altura (sin ventilador) / height (whitout fan)	2245	2245	2565	2895	3230
Longitud / lenght	2235	3012	3012	3270	3625
Anchura (inc.motor) / Width (incl. Motor)	1940	1913	1913	2300	1958
Motores / motors	kW	kW	kW	kW	kW
cribas / screens	1,5	2,2	2,2	1,5	1,1
Ventilador / fan	5,5	5,5	7,5	7,5	11
Rodillo de alimentacion / feeding roller	0,75	0,75	0,75	1,1	2,2
Volumen de aire / air volum	m3	m3	m3	m3	m3
Antes y despues succion / pre and after suction	6400	10600	10600	11000	15000
Peso / weight (kg)	1610	1935	2140	2310	3035
volume de carga / freight volume (m3)	11	15	17	22	25

Ballarini Socama is a registered Brand of Nikami

* Nos reservamos el derecho de efectuar modificaciones en nuestros fabricados, sin previo aviso.
 * We reserve the right to make any modifications in our products or designs, without any notice.

A new world of possibilities that you never dreamed of



Pre-Limpiadora de cereales CL-240
 Pre-Screen Cleaner CL-240

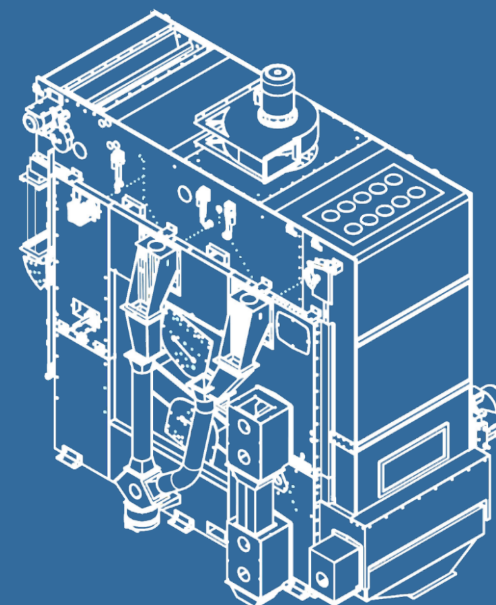

Engineering 2.1 – Where technology meets people

